

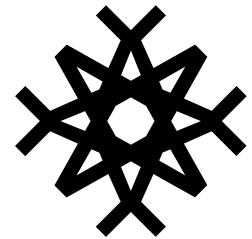

WATER-POWERED DRILLING

TECHNICAL SPECIFICATION: W120 HAMMER



wassara

The Wassara technology uses water to power the DTH hammer. This makes it the ideal choice for drilling in sensitive areas as well as for drilling long straight holes. The water-powered hammer is capable of penetrating almost any formation while maintaining speed and accuracy.

Technical specifications – W120.110	
Length A	1 590 mm (62.6")
Length B	1 495 mm (59")
Diameter C	Ø 126 / 136 / 148 mm (5,0 / 5,5 / 6,0")
Size D 	90 mm (3.5")
Weight (excl. drill bit)	99 kg (218 lbs)
Bit diameter	Ø 130 / 140 / 152 mm (5,0 / 5,5 / 6,0")
Operating pressure interval	60 - 180 bar (870 - 2 610 psi)
Water consumption interval	175 - 445 l/min (45 - 118 USgpm) new to worn
Frequency at maximum operating pressure	54 Hz (3 240 blows/min)
Feed force, formation dependant	12 000 - 24 000 N (2 700 - 5 400 lbf)
Rotation speed, formation dependant	45 - 75 rpm
Rotation torque, formation dependant	1 500 - 3 000 Nm (1 100 - 2 210 lbf-ft)
Drill rod	Wassara Drill rod Ø 102 mm (4"), Thread API 3½" Reg
Recommended water pump	WASP200D / WASP200E VSD 610 l/min (160 USgpm) @ 200 bar (2 900 psi)
Bit shank	Wassara 350

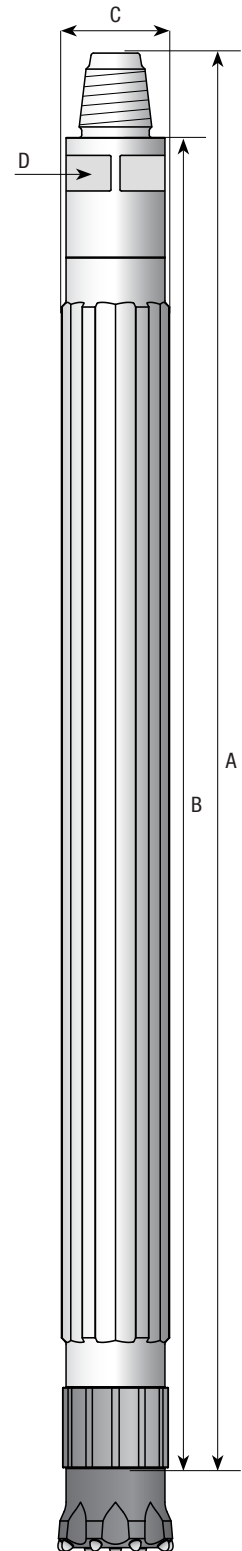

WATER PRESSURE/FLOW CHART

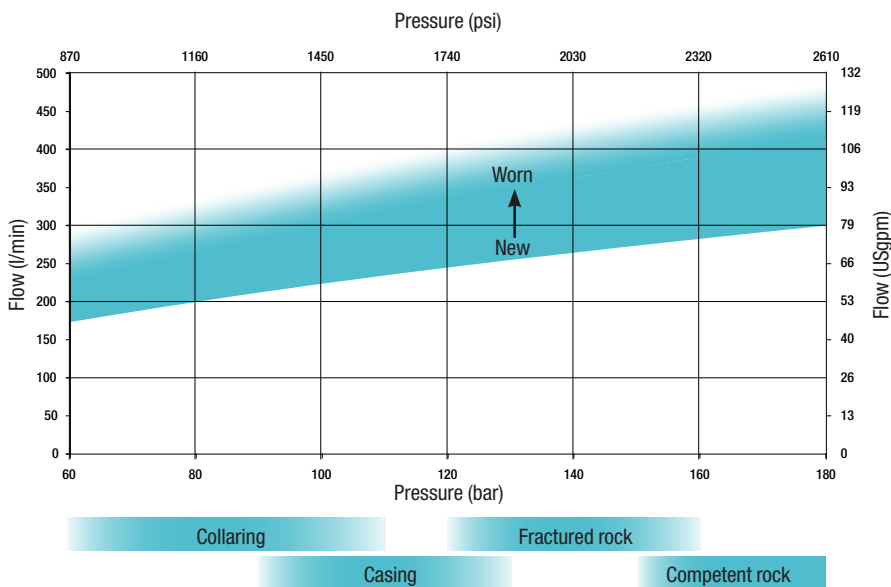

PARTS LIST: W120.110

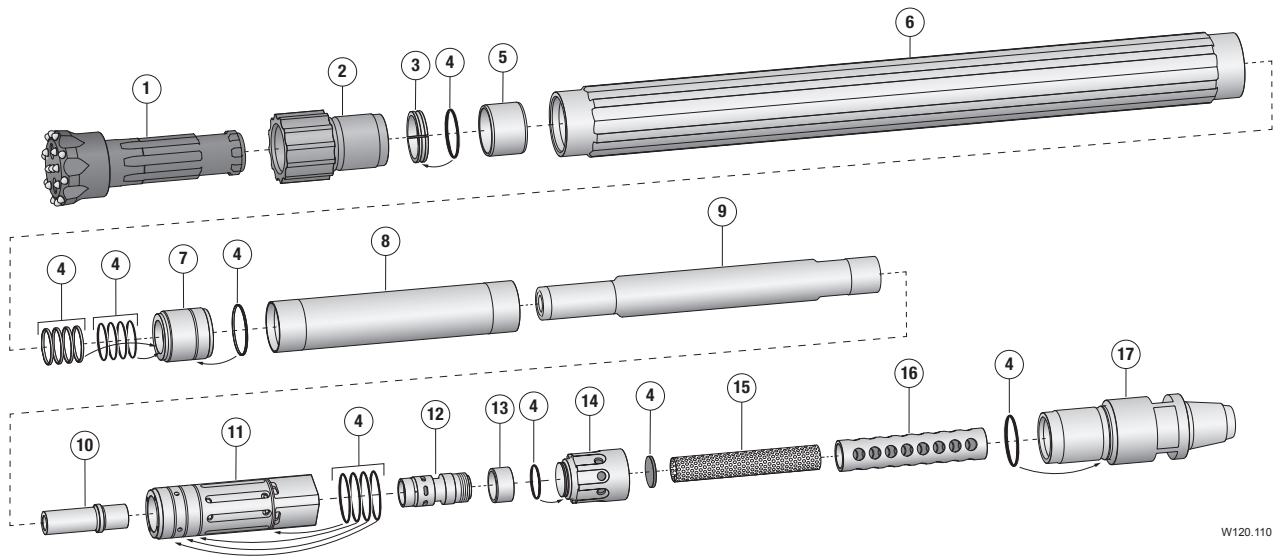

W120.110

Pos	Detail	Part no
	Hammer W120, Ø 126 mm	1001070-126
	Hammer W120, Ø 136 mm	1001070-136
	Hammer W120, Ø 148 mm	1001070-148
1	Drill bit Ø 130 mm, Convex SB	3000013
	Drill bit Ø 140 mm, Convex SB	3000059
	Drill bit Ø 152 mm, Convex SB	3000061
2	Chuck	1000547
3	Bit retainer	1002880
4	Seal kit	1,2 1002079
5	Guide sleeve	1000549
6	Hammer case Ø 126 mm	1001057-126
	Hammer case Ø 136 mm	1001057-136
	Hammer case Ø 146 mm	1001057-148

Pos	Detail	Part no
7	Piston bushing	1,2 1001059
8	Inner tube	1001061
9	Piston	1,2 1001060
10	Sliding case	1001063
11	Valve house	2 1001062
12	Valve	2 1001064
13	Sleeve	1001065
14	Guided lid	1001066
15	Filter	1,2 1001130
16	Filter support	1001068
17	Backhead API 3 1/2" Reg pin	1001067

Spare part kit 1

1002221

Spare part kit 2

1002222

1400022, W120.110 product data sheet, 2017.01. All specifications can be changed without notice.