

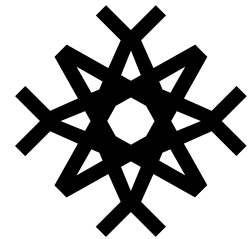

WATER-POWERED DRILLING

TECHNICAL SPECIFICATION: W50.210 HAMMER



Wassara

The Wassara technology uses water to power the DTH hammer. This makes it the ideal choice for drilling in sensitive areas as well as for drilling long straight holes. The water-powered hammer is capable of penetrating almost any formation while maintaining speed and accuracy.

Technical specifications – W50.210	
Length A	950 mm (37.4")
Length B	897 mm (35.3")
Diameter C	Ø 56 / 60 mm (2.2 / 2.4")
Size D 	36 mm (1.4")
Weight	13.5 kg (29.8 lbs)
Bit diameter	Ø 60 / 64 mm (2.4 / 2.5")
Operating pressure interval	50 - 170 bar (725 - 2 465 psi)
Water consumption interval	45 - 150 l/min (12 - 40 USgpm) new to worn
Frequency at maximum operating pressure	75 Hz (4 500 blows/min)
Feed force, formation dependant	3 000 - 6 000 N (675 - 1 350 lbf)
Rotation speed, formation dependant	100 - 200 rpm
Rotation torque, formation dependant	200 - 300 Nm (147.5 - 221 lbf-ft)
Drill pipe	W Drill Pipe Ø 48 mm (1.9"), Thread NC 13
Recommended water pump	WASP50, 150 l/min (40 USgpm) @ 200 bar (2 900 psi)
Bit shank	Wassara 2

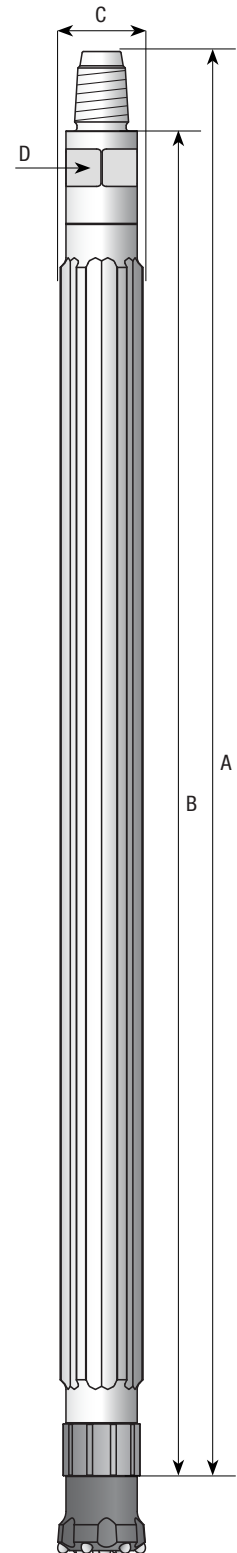

WATER PRESSURE/FLOW CHART

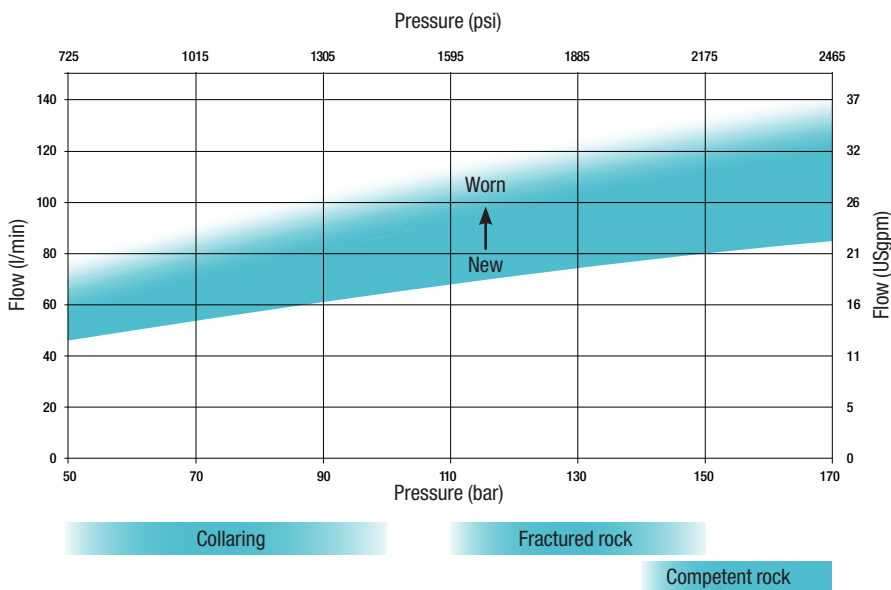

PARTS LIST: W50.210

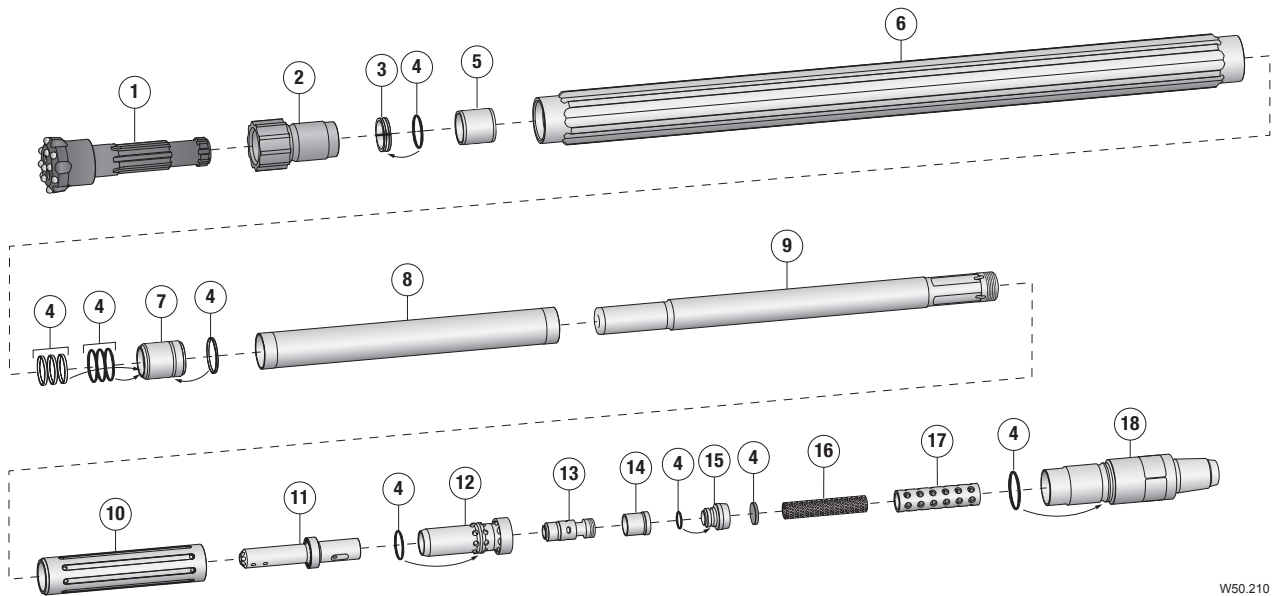

W50.210

Pos	Detail	Part no
*	Hammer W50, Ø 56 mm	1000680-56
	Hammer W50, Ø 60 mm	1000680-60
1*	Drill bit Ø 60 mm, Flat face SB	3000015
	Drill bit Ø 64 mm, Flat face SB	3000017
2	Chuck	1000819
3	Bit retainer	1002875
4	Seal kit	1, 2 1002076
5	Guide sleeve	1000304
6	Hammer case Ø 56 mm	1000678-56
	Hammer case Ø 60 mm	1000678-60
7	Piston bushing	1, 2 1001221

*Standard size, more models available on request

Pos	Detail	Part no
8	Inner tube	1000679
9	Piston	1, 2 1000681
10	House retainer	2 1000311
11	Sliding case	2 1500240
12	Valve house	2 1000315
13	Valve	2 1000317
14	Sleeve	2 1000496
15	Lid	1000318
16	Filter	1, 2 1500288
17	Filter support	1000319
18	Backhead NC13 pin	1000321

Spare part kit 1	1002215
Spare part kit 2	1002216