

# WATER-POWERED DRILLING

## TECHNICAL SPECIFICATION:

### WASSARA DUPLEX DRILL TUBES

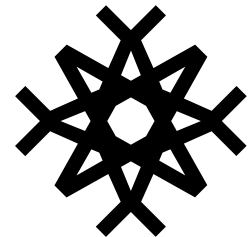

Wassara

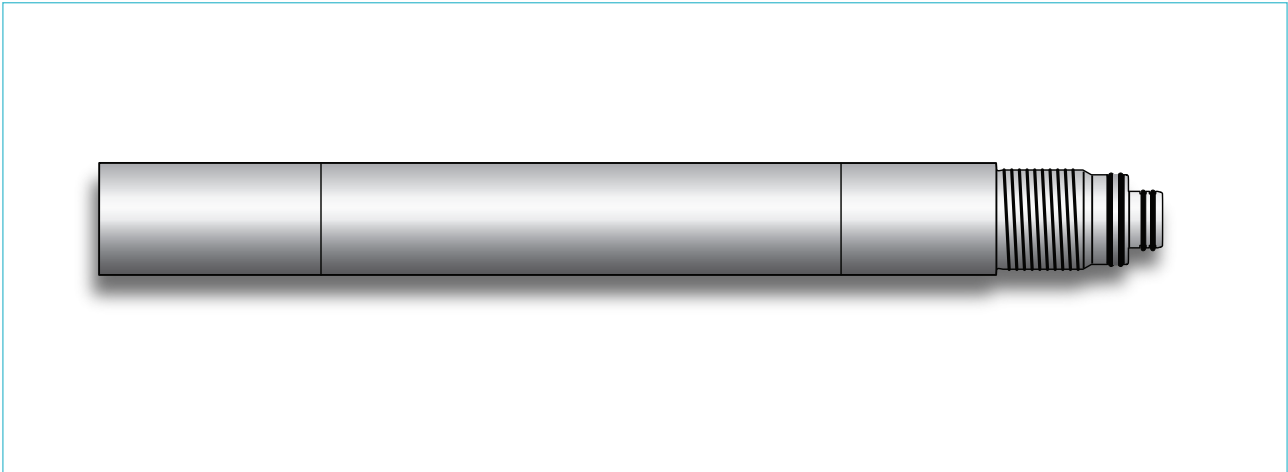

**Wassara Drill Tubes** are designed for maximum productivity optimal service life and to be easy to use. 4 seals are placed in the pin side of the tube to seal of any water and grout leakage. Material choices, heat treatments and production methods are all state of the art. Wassara duplex tubes have two channels with the inner designated for grout or any other substance (e.g. for precutting) and the outer designated for water used to power the hammer.

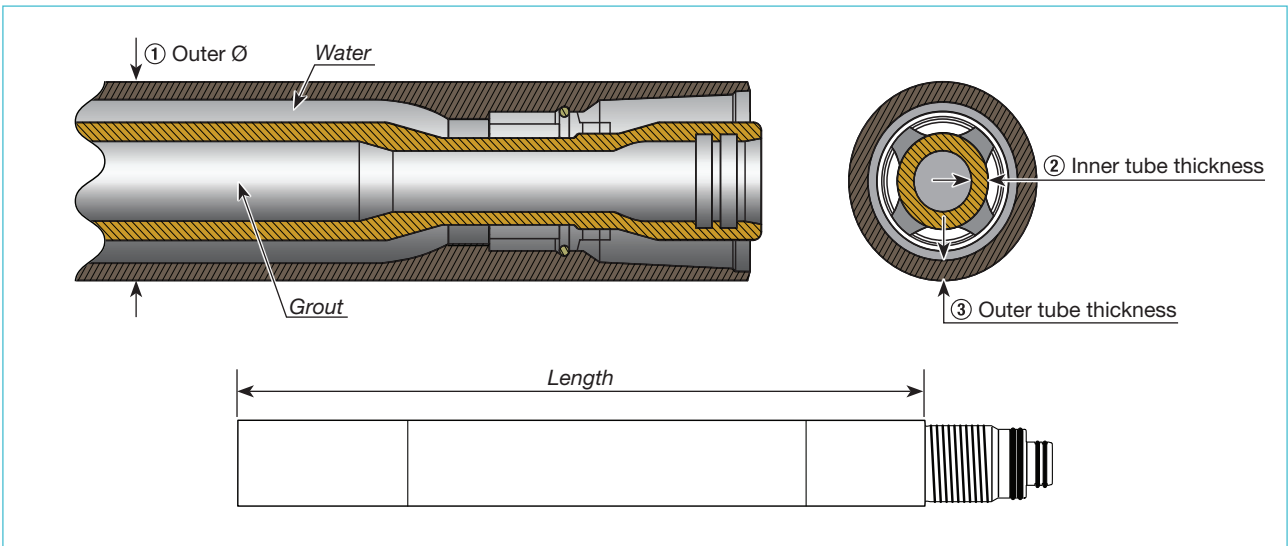

① Outer diameter	Hammer	Thread box	Thread pin	② Inner tube thickness	③ Outer tube thickness	Length	Weight	Part number
114.3 mm (4 1/2")	W100 JG	Wassara JG thread	Wassara JG thread	9.1 mm	8.8 mm	1.0 m	38 kg	4000088
						2.0 m	72 kg	4000089
						3.0 m	106 kg	4000090

Seal kit	1002803
----------	---------

1400096, Wassara Duplex Drill Tubes product data sheet, 2010.01. All specifications can be changed without notice.