

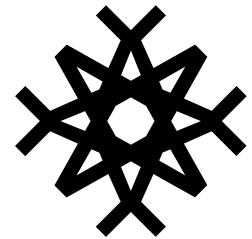

WATER-POWERED DRILLING

TECHNICAL SPECIFICATION: W100 HAMMER



Wassara

The Wassara technology uses water to power the DTH hammer. This makes it the ideal choice for drilling in sensitive areas as well as for drilling long straight holes. The water-powered hammer is capable of penetrating almost any formation while maintaining speed and accuracy.

Technical specifications – W100.131	
Length A	1 306 mm (51.4")
Length B	1 230 mm (48.4")
Diameter C	Ø 111 / 116 / 123 mm (4.4 / 4.6 / 4.8")
Size D 	64 mm (2.5")
Weight (excl. drill bit)	56.5 kg (124.6 lbs)
Bit diameter	Ø 115 / 120 / 127 mm (4.5 / 4.7 / 5.0")
Operating pressure interval	60 - 180 bar (870 - 2 610 psi)
Water consumption interval	130 - 354 l/min (34 - 94 USgpm) new to worn
Frequency at maximum operating pressure	65 Hz (3 900 blows/min)
Feed force, formation dependant	8 000 - 20 000 N (1 800 - 4 500 lbf)
Rotation speed, formation dependant	50 - 90 rpm
Rotation torque, formation dependant	1 000 - 2 000 Nm (740 - 1 480 lbf-ft)
Drill rod	Wassara Drill rod Ø 89 mm (3½"), Thread API 2 3/8" Reg
Recommended water pump	WASP100D / WASP100E VSD, 360 l/min (95 USgpm) @ 200 bar (2 900 psi)
Bit shank	Wassara 340

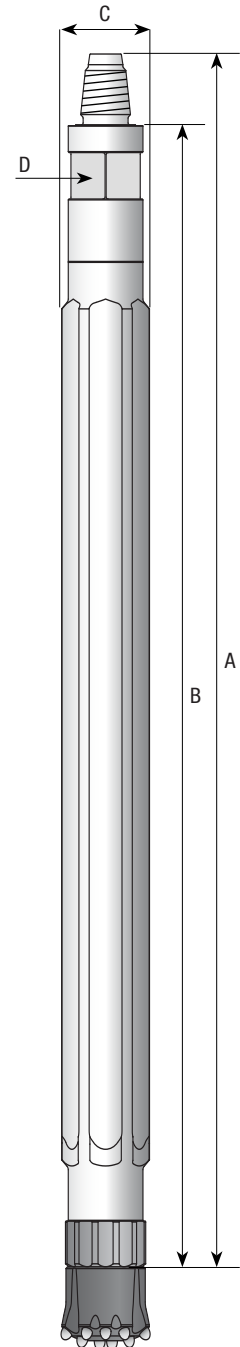

WATER PRESSURE/FLOW CHART

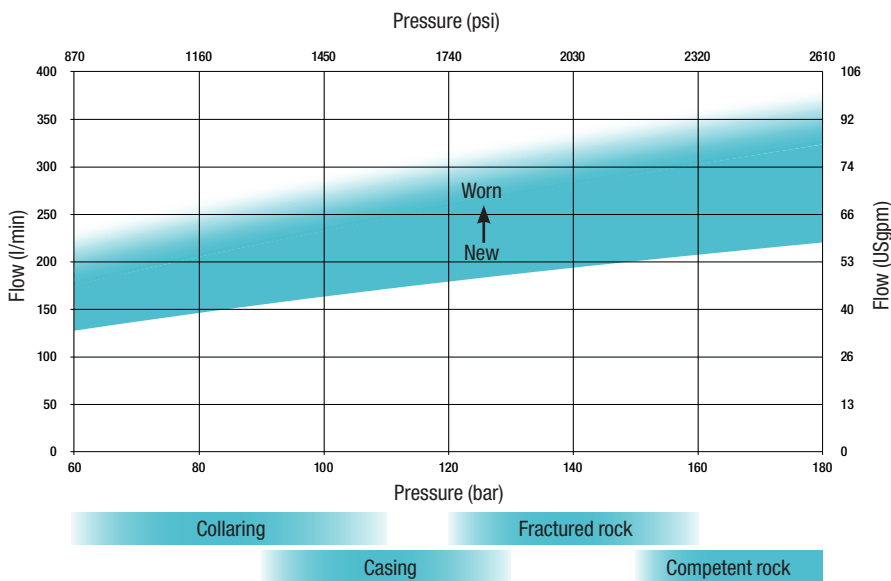

PARTS LIST: W100.131

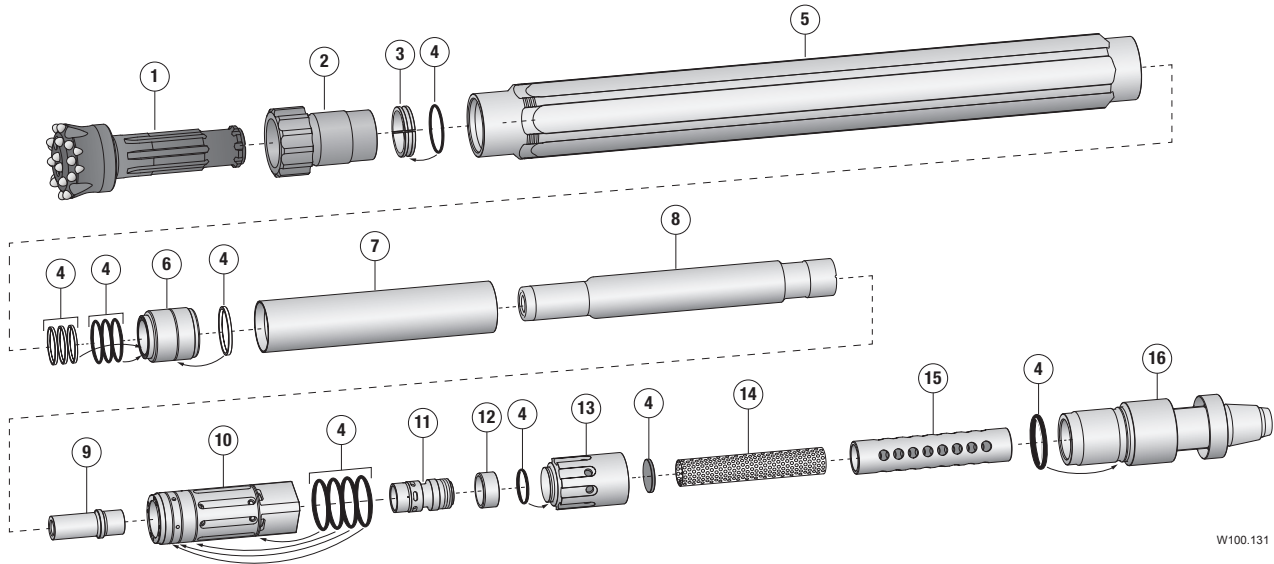

W100.131

Pos	Detail	Part no
	Hammer W100, Ø 111 mm	1003490 -111
	Hammer W100, Ø 116 mm	1003490 -116*
	Hammer W100, Ø 123 mm	1003490 -123*
1	Drill bit Ø 115 mm, Speed SB	3000021
	Drill bit Ø 120 mm, Convex SB	3000029
	Drill bit Ø 127 mm, Convex SB	3000031
2	Chuck	1000803
3	Bit retainer	1002879
4	Seal kit	1,2 1003493
5	Hammer case Ø 111 mm	1500787-111
	Hammer case Ø 116 mm	1500787-116
	Hammer case Ø 123 mm	1500787-123
6	Piston bushing	1,2 1501115

Pos	Detail	Part no
7	Inner tube	1000129
8	Piston	1,2 1501124
9	Sliding case	0043007
10	Valve house	2 0013008
11	Valve	2 1000345
12	Sleeve	1000165
13	Guided lid	1000999
14	Filter	1,2 0040613
15	Filter support	0030337
16	Backhead API 2 3/8" Reg Pin	1000292

<i>Spare part kit 1</i>	1003491
<i>Spare part kit 2</i>	1003492

* Available on request